



SIDDHARTH GROUP OF INSTITUTIONS :: PUTTUR
Siddharth Nagar, Narayanavanam Road – 517583

QUESTION BANK (DESCRIPTIVE)

Subject with Code: Engineering Mechanics (18CE0101)
Course, Year, Semester & Branch: B. Tech -I Year II Sem (ECE)
Regulation: R18

UNIT –I

FORCES & FORCE SYSTEMS

- (a) Classify different system of forces with suitable examples. [5 M]
(b) The resultant of the two forces, when they act at an angle of 60° is 14 N. If the same forces are acting at right angles, their resultant is $\sqrt{137}$ N. Determine the magnitude of the two forces. [5 M]
- (a) State and prove parallelogram law of forces. [5 M]
(b) A system of forces are acting at the corners of a rectangular block as shown in Fig.1. Determine the magnitude and direction of the resultant force. [5 M]

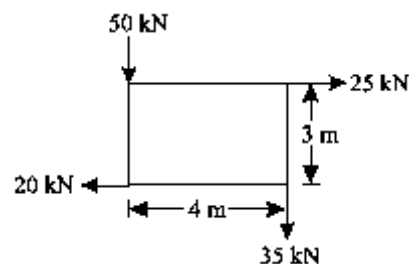

Fig.1

- State and prove Varignon's theorem. [10 M]
- A gusset plate of roof truss is subjected to forces as shown in Fig.2. Determine the magnitude of the resultant force and its orientation measured counter clockwise from the positive x-axis. [10 M]

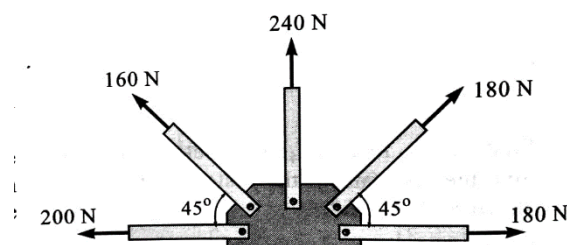

Fig.2

- A system of connected flexible cable shown in Fig.3 is supporting two vertical forces 200 N and 250 N at points B and D. Determine the forces in various segments of the cable. [10 M]

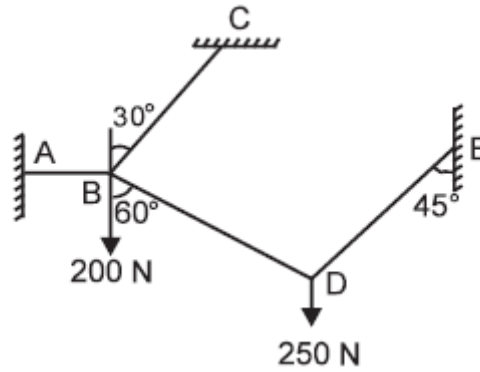

Fig. 3

6. (a) Explain free body diagram with example. [5 M]
 (b) State and prove Lami's theorem. [5 M]
7. A beam ABCDE hinged at A and supported on rollers at D, is loaded as shown in Fig.4. Find the reactions at A and D. [10 M]

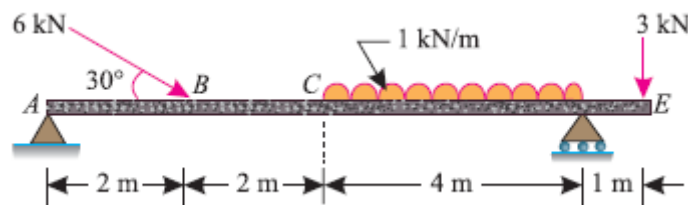

Fig.4

8. A simply supported beam AB of span 6 m is loaded as shown in Fig.5. Determine the reactions at A and B. [10 M]

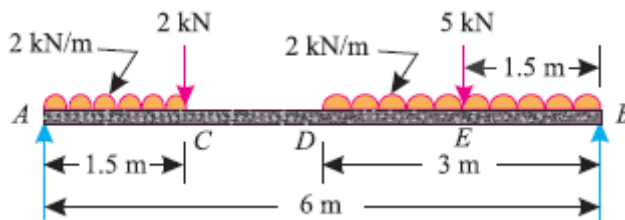

Fig.5

9. A simply supported beam AB of span 4.5 m is loaded as shown in Fig.6. Find the support reactions at A and B. [10 M]

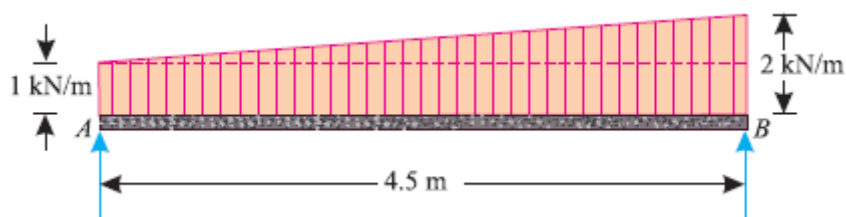

Fig.6

10. (a) Classify different types of Force Systems. [10 M]
 (b) Write down the Applications of Forces.
 (c) What are the different types of Supports?
 (d) What are the different types of Beams?
 (e) Define Equilibrium and write its equations.

UNIT –II
FRICTION

1. (a) State laws of friction. [6 M]
 (b) Explain *Cone of Friction* with a neat sketch. [4 M]
2. A body, resting on a rough horizontal plane, required a pull of 180 N inclined at 30° to the plane just to move it. It was found that a push of 220 N inclined at 30° to the plane just moved the body. Determine the weight of the body and the coefficient of friction. [10 M]
3. Define the following: [10 M]
 (a) Limiting Force of Friction
 (b) Kinetic Friction
 (c) Co-efficient of Friction
 (d) Angle of Friction
 (e) Angle of Repose
4. Find the least force required to drag a body of weight 'W' placed on a rough inclined plane having inclination ' α ' to the horizontal. The force is applied to the body in such a way that it makes an angle ' Θ ' to the inclined plane and the body is on the point of motion up the plane. [10 M]
5. Find the value of ' Θ ' if the block 'A' and 'B' shown in Fig.7 have impending motion. Given block A = 20 kg, block B = 20 kg, $\mu_A = \mu_B = 0.25$. [10 M]

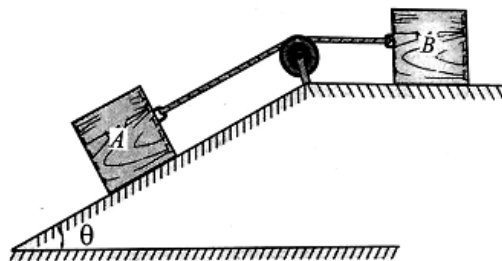

Fig.7

6. Two blocks W_1 and W_2 resting on two inclined planes are connected by a horizontal bar AB as shown in Fig.8. If W_1 is equals 1000 N, determine the maximum value of W_2 for which the equilibrium can exists. The angle of limiting friction is 20° at all rubbing faces. [10 M]

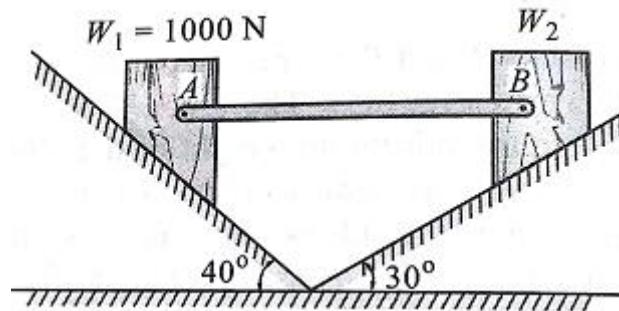

Fig.8

7. Block A of mass 30 kg rests on block B of mass 40 kg as shown in Fig.9. Block A is restrained from moving by a horizontal rope tied at point C, what force P applied to the plane inclined at 30° with horizontal is necessary to start block B down the plane. Take coefficient of friction for all surfaces as 0.35. [10 M]

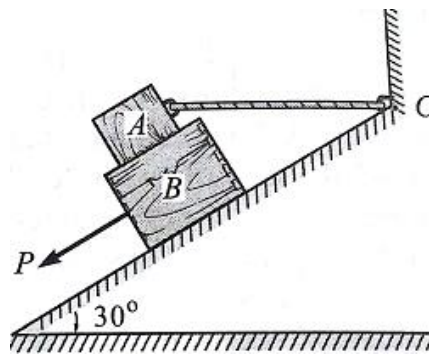

Fig.9

8. A ladder 5 meters long rests on a horizontal ground and leans against a smooth vertical wall at an angle 70° with the horizontal. The weight of the ladder is 900 N and acts at its middle. The ladder is at the point of sliding, when a man weighing 750N stands on a rung 1.5 meter from the bottom of the ladder. Calculate the coefficient of friction between the ladder and the floor.

[10 M]

9. A ladder of length 4 m, weighing 200 N is placed against a vertical wall as shown in Fig.10. The coefficient of friction between the wall and the ladder is 0.2 and that between floor and the ladder is 0.3. The ladder, in addition to its own weight, has to support a man weighing 600 N at a distance of 3 m from A. Calculate the minimum horizontal force to be applied at A to prevent slipping.

[10 M]

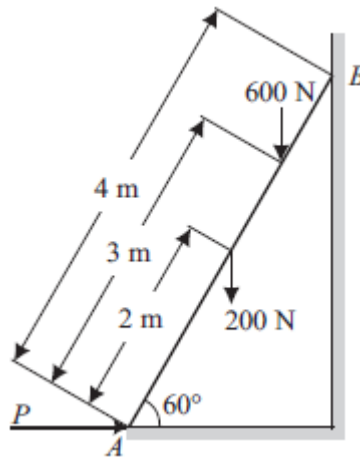

Fig.10

10. a) Write short note on differential screw jack with neat sketch. [6 M]
 b) A screw jack raises a load of 40 KN. The screw is square threaded having three threads per 20 mm length and 40 mm in diameter. Calculate the force required at the end of a lever 400 mm long measured from the axis of the screw, if the coefficient of friction between screw and nut is 0.12. [4 M]

UNIT-III

CENTROID & CENTRE OF GRAVITY

1. A uniform lamina shown in Fig. 11 consists of a rectangle, a circle and a triangle. Determine the center of gravity of the lamina. All dimensions are in mm [10 M]

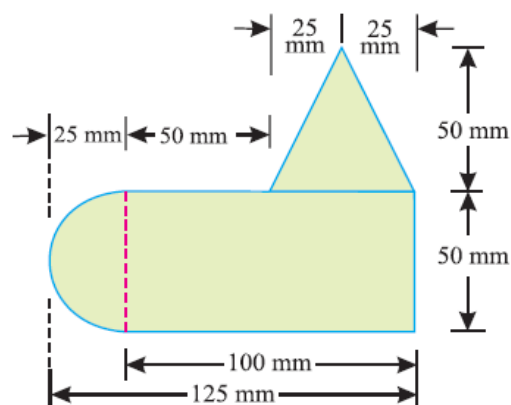

Fig. 11

2. A semicircle of 90 mm radius is cut out from a trapezium as shown in Fig.12 Find the position of the Centre of gravity of the figure. [10 M]

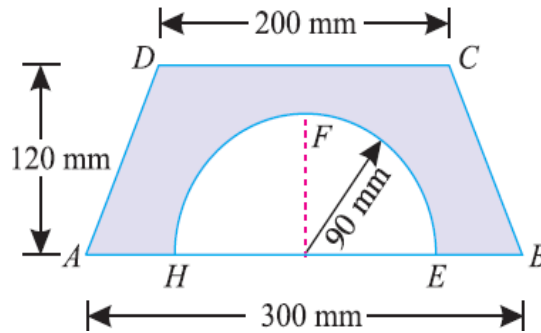

Fig.12

3. Locate the centroid of the uniform wire bent as shown in Fig.13 [10 M]

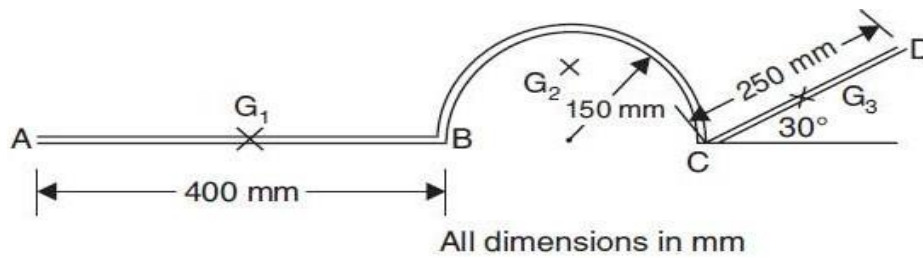

Fig.13

4. Determine the centroid of the area shown in Fig. 14 with respect to the axis shown [10 M]

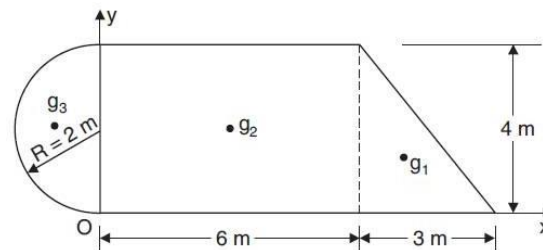

Fig. 14

5. An I-section is made up of three rectangles as shown in Fig.15 Find the moment of inertia of the section about the horizontal axis passing through the center of gravity of the section.

[10 M]

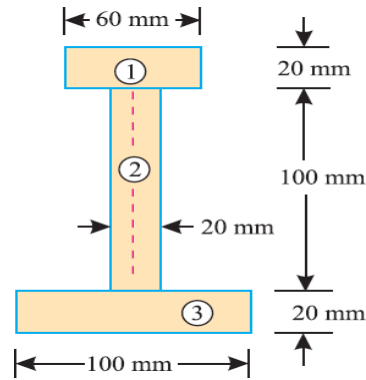

Fig.15

6. Find the centroid of the section of a masonry dam as shown in the Fig.16. [10 M]

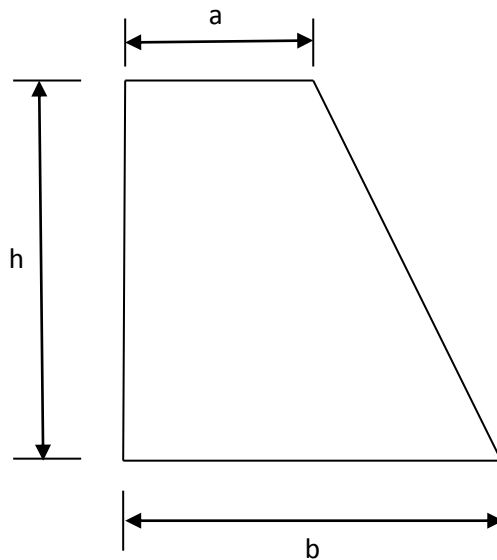

Fig.16

7. Determine the centroid of the remaining portion of a circular sheet of metal of radius 50cm when a hole of 10cm radius is taken out from the Centre of the circular disc along its horizontal diameter as shown in fig.17 [10 M]

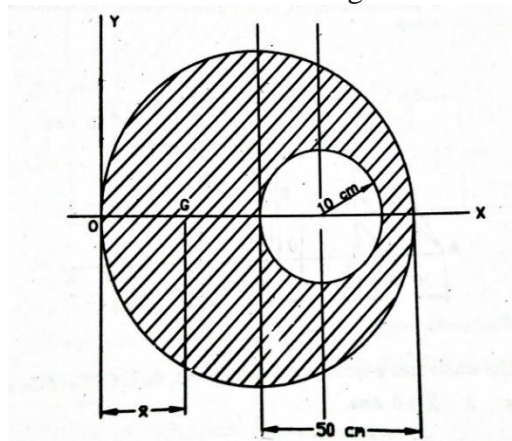

Fig.17

8. Find the center of gravity of a channel section 100 mm × 50 mm × 15 mm as shown in

Fig.18

[10 M]

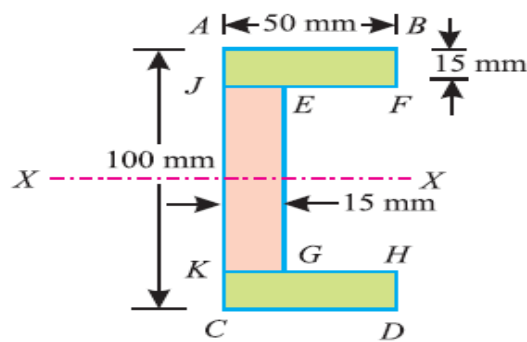

Fig.18

9. An I-section as shown in Fig.19 has the following dimensions in mm units:

Bottom flange = 300×100

Top flange = 150×50

Web = 300×50

Determine mathematically the position of center of gravity of the section. [10 M]

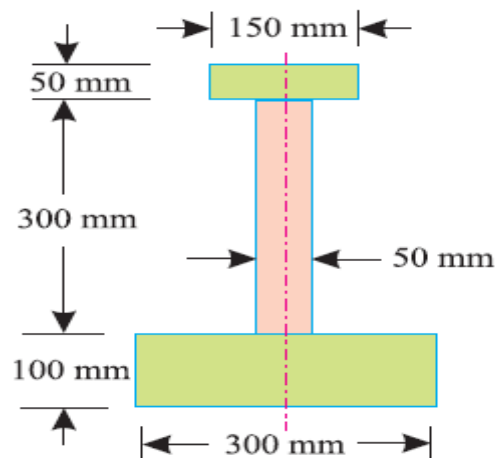

Fig.19

10. Find the center of gravity of the shaded area shown in below Fig.20 with reference to X-Y co-ordinate system [10 M]

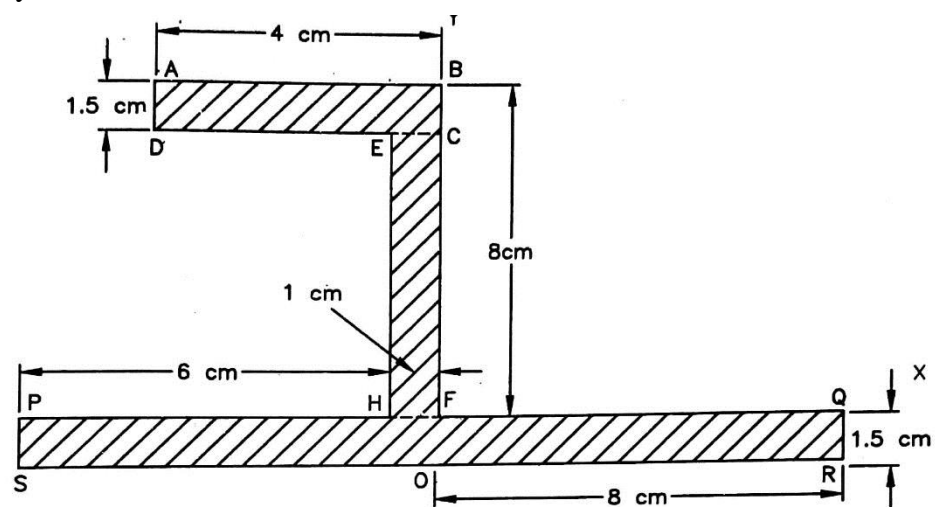

Fig.20

UNIT-IV
MOMENT OF INERTIA

1. Find the moment of inertia of the lamina with a circular hole of 30 mm diameter about the axis AB as shown in Fig.21 [10 M]

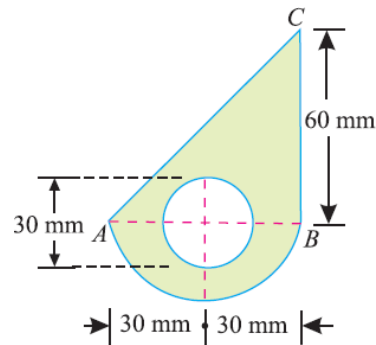

Fig.21

2. Prove the parallel axis theorem in the determination of moment of inertia of areas with the help of a neat sketch. [10 M]
3. Derive an equation for moment of inertia of the following sections about centroidal axis:
- A rectangular section
 - A triangular section from its base [10 M]
4. Find the moment of inertia of a T-section with flange as 150 mm \times 50 mm and web as 150 mm \times 50 mm about X-X and Y-Y axes through the center of gravity of the section as shown in fig..22 [10 M]

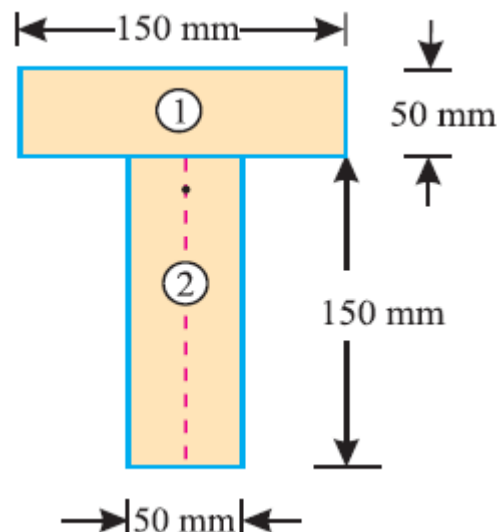

Fig.22

5. An I-section is made up of three rectangles as shown in Fig. 23. Find the Moment of inertia of the section about the horizontal axis passing through the center of gravity of the section. [10 M]

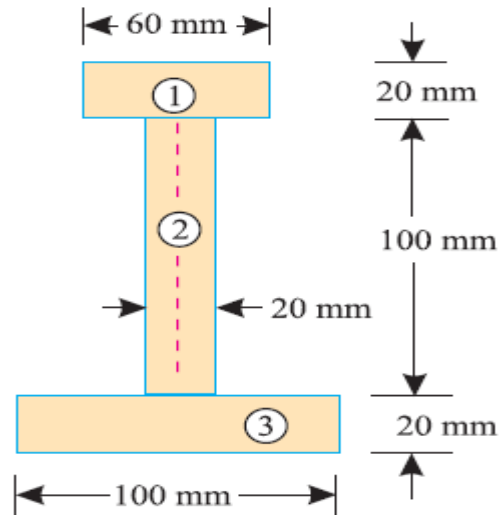

Fig.23

6. Define the following terms [10 M]
- (a) Parallel Axis Theorem
 - (b) Perpendicular Axis Theorem
 - (c) Moment of Inertia
 - (d) Polar Moment of Inertia
 - (e) Radius of Gyration
7. A rectangular hole is made in a triangular section as shown in Fig.24. Determine the moment of inertia of the section about X-X axis passing through its center of gravity and the base BC. [10 M]

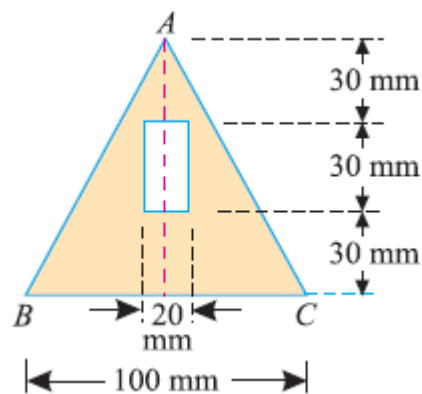

Fig.24

8. Find the moment of inertia of a hollow section shown in Fig.25 about an axis passing through its center of gravity or parallel X-X axis. [10 M]

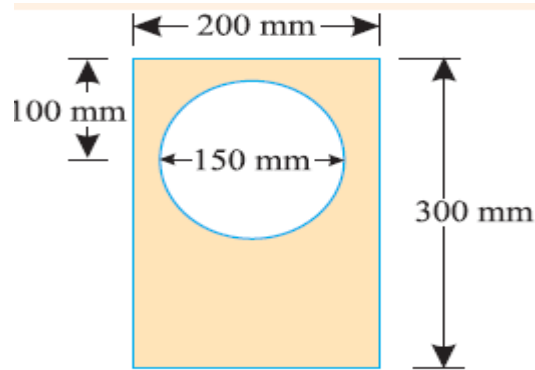

Fig.25

9. Find the moment of inertia about the centroidal X-X and Y-Y axes of the angle section shown in Fig.26 [10 M]

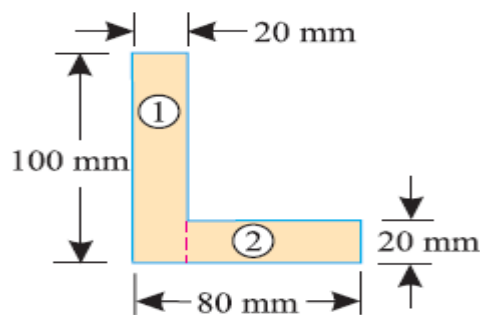

Fig.26

10. Compute the second moment of area of the channel section shown in Fig. 27 about centroidal axis x-x and y-y. [10 M]

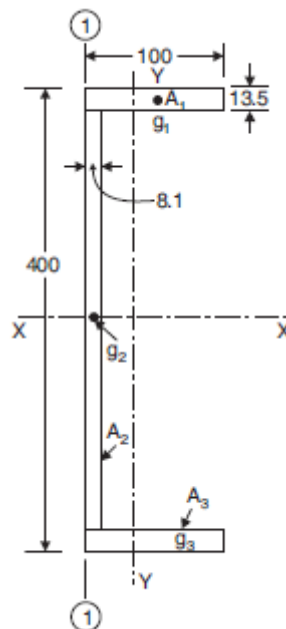

Fig.27

UNIT-V
ANALYSIS OF PERFECT TRUSSES

1. Find the forces in the members of a truss as shown in fig.28 [10 M]

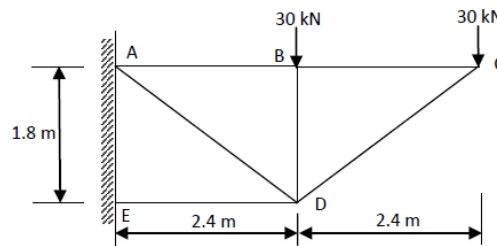

fig.28

2. Analyze the members of a inclined truss loaded as shown in fig.29 [10 M]

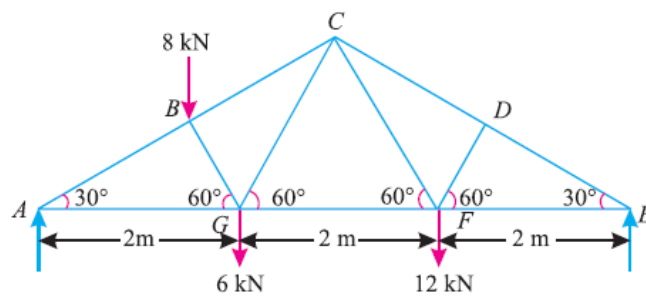

fig.29

Determine the nature and magnitude of the forces in the members BC, GC and GF of the truss.

3. A plane is loaded & supported as shown in fig.30. Determine the nature and magnitude of the forces in the members' 1,2 and 3. [10 M]

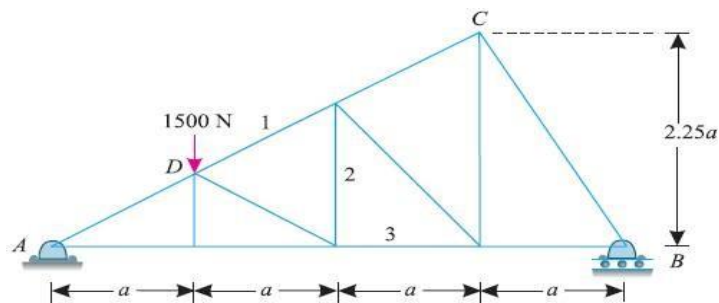

fig.30

4. A cantilever truss is loaded as shown in Fig.31. Find the value W, which would produce the force of magnitude 15 kN in the member AB. [10 M]

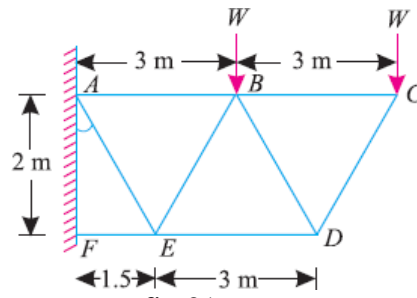

fig.31

5. Determine the forces in all the members of the truss shown in Fig.32 [10 M]

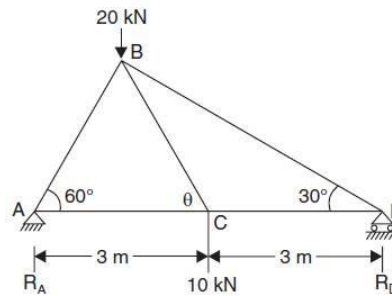

fig.32

6. Explain the procedure to find forces in members of truss by using method of joints.
7. Fig 33 shows a framed structure of 4 m span and 1.5 m height subjected to two-point loads at B and D. [10 M]

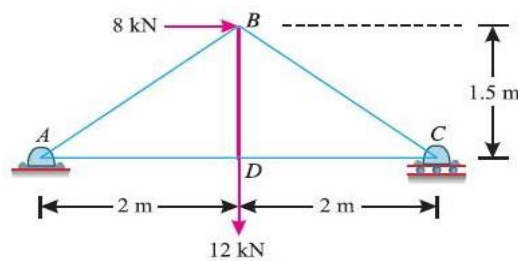

fig.33

8. Explain the procedure to find forces in members of truss by using method of sections. [10M]
9. A king post truss of 8 m span is loaded as shown in Fig.34. Find the forces in each member of the truss and tabulate the results. [10 M]

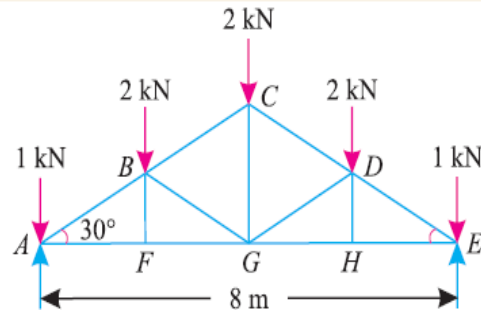

fig.34

10.

- What is a cantilever truss? How will you find out its reactions?
- State the assumptions made in the analysis of pin jointed trusses.
- How method of joint differs from the method of section in the analysis of pin jointed trusses?
- What is meant by perfect frame?
- What are the types of vibrations?

[10 M]